

BZ-Zyklon

Flüssigkeitsabscheider
Separator for separation of liquids

für Biogasanlagen - Flanschanschluß
for biogas plants - flange connection

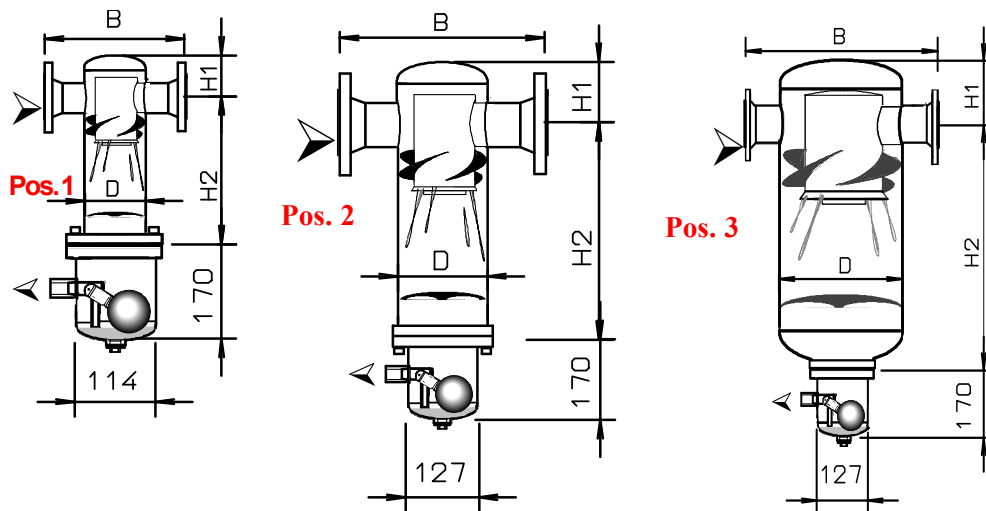

Material:
VA-Stahl (1.4571), gebeizt und passiviert
Stainless-Steel (1.4571), pickled and passivate

Abnahme:
gem. DGRL 2014/68 + AD2000
Inspection: acc. PED 2014/68 + AD2000

Anschlüsse:
Flansche nach EN 1092-1
connection: flanges acc. EN 1092-1

Designtemperatur: -10 / +120 °C
Design temperature:

Type BZ	DN	D Ø	H1	H2	B	bar g	G - Ltr.	kg	
15	15	63,5	90	360	200	16	2,3	11	Pos. 1
20	20	63,5	90	360	210	16	2,3	12	Pos. 1
25	25	101,6	100	360	240	16	4,5	23	Pos. 1
32	32	101,6	100	360	260	16	4,5	25	Pos. 1
40	40	127	100	450	340	10	8	26	Pos. 2
50	50	152,4	120	450	360	10	11	32	Pos. 2
65	65	177,8	140	460	400	10	15	36	Pos. 2
80	80	219,1	170	480	460	10	25	48	Pos. 2
100	100	267	180	600	560	10	42	67	Pos. 2
125	125	323,9	230	710	610	10	72	94	Pos. 3
150	150	368	240	810	700	10	104	122	Pos. 3
175	200	419	280	960	860	9	158	110	Pos. 3
200	200	500	290	980	900	8	229	124	Pos. 3
225	250	550	330	1210	950	6	338	160	Pos. 3
250	250	600	355	1300	990	6	433	180	Pos. 3

G-Ltr: Gesamtinhalt – volume / S-Ltr.: Sammelraum – collecting room
Ausführung incl. autom. Ableiter HS125 / Version incl. automatic trap HS125
Sonderausführungen auf Anfrage / Special Version on request



Haub + Schöllnhammer Apparatebau GmbH

Untere Industriestr. 55 * 57250 Netphen

Phone +49 (0) 271 222963-0 * Fax +49 (0) 271 222963-30 * www.haub-schoellnhammer.de * info@haub-schoellnhammer.de