

# BZ-Zyklon

**Flüssigkeitsabscheider**  
**Separator for separation of liquids**

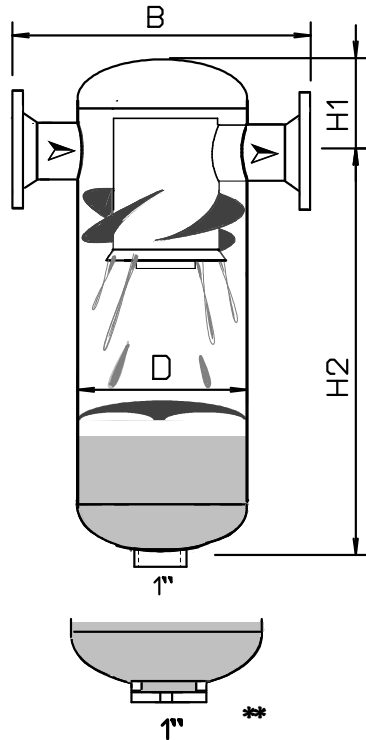

## Standard 15 – 250 Flanschanschluß

*Standard 15 – 250*  
*flange connection*

**Material:**

**Stahl geschweißt, außen grundiert RAL 2002**  
**Steel welding design, outside priming coat RAL 2002**

**Anschlüsse: Flansche nach EN 1092-1**  
**connection: flanges acc. EN 1092-1**

**Abnahme: gem. DGRL 97/23 + AD2000**  
**Inspection: acc. PED 97/23 + AD2000**

**Designtemperatur: -10 / +120 °C**  
**Design temperature:**

\*\* Inspektionsöffnung ab BZ125 / inspection hole from size BZ125 - DN 125

Type BZ	DN	D Ø	H1	H2	B	M	barg	G-Ltr.	S - Ltr.	kg
15	15	63,5	90	360	200	½"	25	1,1	0,4	4,1
20	20	63,5	90	360	210	½"	25	1,1	0,4	4,9
25	25	101,6	100	360	240	1"	25	3,2	0,9	8,1
32	32	101,6	100	450	260	1"	25	3,9	1,7	10,3
40	40	127	110	450	340	1"	16	6,0	2,3	13
50	50	152,4	130	450	360	1"	16	8,9	3,0	19
65	65	177,8	140	480	400	1"	16	13	3,4	21
80	80	219,1	170	480	460	1"	10	22	3,3	26
100	100	267	190	610	520	1"	8	40	8,8	37
125	125	323,9	230	710	610	1"	7	71	11	56
150	150	368	240	810	700	1"	6	103	16	71
175	200	419	280	960	860	1"	6	158	26	118
200	200	500	290	980	900	1"	6	228	35	134
225	250	550	330	1210	950	1"	6	337	65	175
250	250	600	355	1300	990	1"	6	433	80	197

G-Ltr.: Gesamthalt – volume / S-Ltr.: Sammelraum – collecting room  
Sonderausführungen auf Anfrage / Special Version on request



**Haub + Schöllnhammer Apparatebau GmbH**

Hundemstrasse 132 \* 57368 Lennestadt

Phone 0049 (0) 2723 9240-0 \* Fax 0049 (0) 2723 9240-30 \* [www.haub-schoellnhammer.de](http://www.haub-schoellnhammer.de) \* [info@haub-schoellnhammer.de](mailto:info@haub-schoellnhammer.de)