

BZ-Zyklon

Feststoffabscheider
Separator for separation of dust

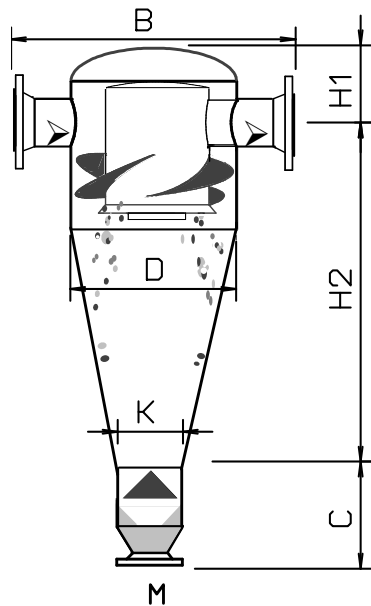

Standard 550 - 950 ohne Behälterflanschen

Standard 550 - 950
without vessel flanges

Material:

Stahl geschweißt, außen grundiert RAL 2002
Steel welding design, outside priming coat RAL 2002

Anschlüsse: Flansche nach EN 1092-1
connection: flanges acc. EN 1092-1

Abnahme: gem. DGRL 97/23 + AD2000
Inspection: acc. PED 97/23 + AD2000

Designtemperatur: -10 / +120 °C
Design temperature:

Type BZ	DN	D Ø	H1	H2	C	K	B	M	barg	G-Ltr.	S - Ltr.	kg
550	600	1200	650	3370	1110	600	1600	DN200	6	3300	250	1056
600	600	1300	700	3700	1300	700	1700	DN200	6	4390	300	1270
650	700	1400	800	4000	1300	700	1800	DN200	6	5420	380	1740
700	700	1500	850	4300	1500	800	1900	DN250	6	6980	550	2034
750	800	1600	950	4610	1500	800	2100	DN250	6	8690	580	2432
800	800	1700	1000	4900	1600	900	2150	DN250	5	10320	650	2738
850	900	1800	1000	5100	1700	900	2250	DN250	5	11170	800	3093
900	900	1900	1000	5400	1800	1000	2300	DN300	5	13390	1000	3425
950	1000	2000	1100	5700	1900	1000	2400	DN300	5	15270	1100	4305

G-Ltr: Gesamtvolumen – volume / S-Ltr.: Sammelraum – collecting room
Sonderausführungen auf Anfrage / Special Version on request



Haub + Schöllnhammer Apparatebau GmbH

Hundemstrasse 132 * 57368 Lennestadt

Phone 0049 (0) 2723 9240-0 * Fax 0049 (0) 2723 9240-30 * www.haub-schoellnhammer.de * info@haub-schoellnhammer.de